

Vibration Exposure for Selected Power Hand Tools Used in Automobile Assembly*

ROBERT G. RADWIN^{a†}, THOMAS J. ARMSTRONG^b, AND ERNST VANBERGEIJK^c

^aDepartment of Industrial Engineering, University of Wisconsin, Madison, WI 53706; ^bCenter for Ergonomics, The University of Michigan, Ann Arbor, MI 48109; ^cBody and Assembly Operations, Ford Motor Company, Dearborn, MI 48121

A practical method for assessing vibration exposure for workers operating vibrating hand tools on an automobile assembly line is presented. Vibration exposure is difficult to assess directly using many fast Fourier transform (FFT) spectral analyzers because of long task cycle times. Exposure time cannot be accurately estimated using time standards because of the high variability between operators and work methods. Furthermore, because workers frequently move about and get into inaccessible spaces, it is difficult to record vibration without interfering with the operation. A work sampling method was used for determining vibration exposure time by attaching accelerometers to the tools and suspending a battery-operated digital data logger from the air hose. Vibration acceleration and frequency spectra for each tool were obtained off-line replicating actual working conditions and analyzed together with exposure time data for determining individual worker vibration exposure. Eight pneumatic vibrating power hand tools, representing tools commonly used in an automobile assembly plant, were studied. Spectra for the rotary and reciprocating power tools had large distinct dominant fundamental frequencies occurring in a narrow frequency range between 35 Hz and 150 Hz. These frequencies corresponded closely to tool free-running speeds, suggesting that major spectral component frequencies may be predicted on the basis of speed for some tools.

The purpose of this paper is to (1) present some practical aspects of occupational hand-arm vibration exposure assessment, (2) identify characteristics of typical vibrating hand tools used in automobile assembly, and (3) determine representative vibration exposures for selected jobs that require operating surface finishing hand tools such as rotary or reciprocating sanders. Vibration is a concern because of the adverse effects of hand-arm vibration

*This work was made possible by grants from the Body and Assembly division of the Ford Motor Company, NIOSH Grant No. 5 R03 OH01852-02, and NIOSH Traineeship Grant No. 1 T15 OH07207-01.

†Address correspondence to Robert G. Radwin, Ph.D., Department of Industrial Engineering, 1513 University Avenue, University of Wisconsin, Madison, WI 53706.

syndrome that are addressed by various exposure guidelines and standards for segmental vibration.⁽¹⁻³⁾ Vibration is also important because of the increasing evidence that operating vibrating hand tools is associated with cumulative trauma disorders of the hand and wrist, such as carpal tunnel syndrome.⁽⁴⁻⁷⁾

Vibration exposure was assessed for selected jobs requiring extensive use of pneumatic vibrating hand tools in an automobile assembly plant. Hand tool operators in automotive assembly are often confronted with a number of ergonomic and physical stresses including hand-arm vibration. While it has been shown that large chipping tools and grinders produce a considerable amount of vibration,⁽⁸⁾ it is less recognized that smaller hand-held pneumatic tools typically used in manufacturing and assembly are also capable of producing significant levels of vibration.⁽⁹⁾

Use of linear integrating vibration measurement equipment is best suited for measuring vibration exposure when the vibration signal is of short duration and its operation varies substantially with time.⁽⁶⁾ In the automobile industry, however, task cycle times are relatively long and may last 1 min or longer. Linear integrating vibration spectrum analyzers having integration periods greater than 1 min are not always readily available. Many digital fast Fourier transform (FFT) spectrum analyzers are capable of computing one-third octave band spectra from sampled data. These analyzers, however, usually have sufficient memory for sampling data over periods much less than 1 min. This time window is often only a few seconds or less for the bandwidth necessary for measuring hand and arm vibration, which is greater than 1250 Hz. Providing that the vibration signal is stationary⁽¹⁰⁾ (i.e., the signal is time-invariant) during tool operation, linear integration over the entire tool operating period is not always necessary. If tool operation time can be accurately determined independently of vibration acceleration, vibration exposure levels can then be computed using transient vibration measurements. Furthermore, vibration measurements can be taken off-line where conditions can be controlled and not interfere with ongoing operations. An FFT-computing spectrum analyzer or microcomputer program capable of spectral analysis can then be used for estimating vibration exposure.

EXPERIMENTAL MATERIALS AND METHODS

Tools

Eight tools commonly used in automotive assembly were studied. These particular power hand tools were selected because they were considered tools used on the assembly line that produced substantial vibration. They included rotary power tools, such as orbital sanders and polishers, and reciprocating tools, such as a jitterbug sander and trimming shear. Tool type, weight, operating speed, and task descriptions are summarized in Table I. Each tool, handle configuration, and hand posture used are illustrated in Figure 1.

Vibration Measurements

Vibration was measured at locations on the tool in closest contact with the hands by mounting accelerometers directly to the handles (Figure 1). Triaxial accelerometers were attached to each tool and vibration was measured in three orthogonal coordinate axes in accordance with the ISO/DIS 5349 hand and arm basicentric coordinate system.⁽⁶⁾ When tools were equipped with accessory handles, or were held using two hands elsewhere on the tool during some operations, vibration measurements were made from these points as well.

Accelerometers were fastened to an aluminum block using a stud screw. The block had a contoured radius on the side in contact with the cylindrical surface of the tools. Panduit™ stainless steel ties were used to strap the accelerometer mount tightly to the handles. A slot was milled into the block to pass the tie which wrapped around the handle or tool body circumference. This technique provided convenient installation and removal of accelerometers.

Tool vibration was measured using Brüel & Kjaer model 4340 triaxial accelerometers having a charge sensitivity of 20 pC/g and Kias-Swiss model 5001 charge amplifiers. A Gen Rad 1557A sinusoidal reference accelerometer calibrator, having a RMS amplitude of 9.81 m/sec² (1 g) at 100 Hz, was used for calibrating accelerometers before and after the tool measurements to verify their integrity. Various abrasives and grits were used, depending on corresponding tool applications in the plant. The work material was sheet metal steel for all tools tested.

Vibration acceleration was measured off-line while each tool was run continuously for at least 60 sec. Vibration waveforms were recorded for off-line signal analysis using a Teac model

R-71 FM cassette tape recorder having a bandwidth of 1250 Hz. Recordings were later digitized using a Metrabyte DASH-16, 12-bit analog-digital converter and IBM-PC microcomputer. Constant bandwidth spectra were computed using sixteen 1024-point acceleration time series and a sample rate of 4000 samples per second. A low-pass filter was installed for antialiasing with a cutoff frequency of 1250 Hz. Each time series was weighted using a Hanning window, transformed to the frequency domain using an FFT algorithm, ensemble averaged, and the spectrum magnitude computed. To remove any further possibility of aliasing, only the first 320 points of the spectrum having frequency components up to 1250 Hz were considered.

One-third octave band spectra were obtained using a Wavetek model 444A FFT computing analyzer. Frequency weighted RMS acceleration in each coordinate axis was computed using one-third octave band frequency acceleration levels according to the ISO 5349 standard. Total RMS weighted and unweighted acceleration levels were computed using the vector sum of RMS acceleration in each coordinate axis.

Exposure Time Measurements

Exposure time was measured by recording tool operation time at a fixed sample rate during actual use on the assembly line. This technique was similar to work sampling methods used in conventional industrial engineering time study methodology. The exposure time data acquisition procedure is shown in Figure 2. A unidirectional accelerometer was attached to each tool using similar methods previously described in this paper. The accelerometer output was amplified, conditioned, digitized, and stored using a battery-operated, digital data logger. The accelerometer output was amplified and integrated using a time constant of 4 sec. The data logger was a self-contained data acquisition system with an eight-bit analog-digital converter with the capacity to store 16 384 data samples. The unit was battery operated, which made it possible to package the entire system in an enclosure 14 cm x 9 cm x 3.5 cm, weighing 0.3 kg, and small enough to suspend it from a hand tool pneumatic air hose. This prevented interference with the worker and ongoing operations.

Tool operation time was sampled at a rate of 1 or 2 samples per second, depending upon the observation period and available digital data logger memory. Because of the long time constant, the sample rate was slow enough to store more than 4½ hr of work sampling using the data logger. The integrated signal was ob-

TABLE I
Description of Tools Surveyed and Associated Tasks

Tool Type	Weight (kg)	Free Running	Task Description
		Speed (rpm)	
(A) Hand grip orbital sander	2.0	8500	metal finishing
(B) Palm grip orbital sander	1.8	8000	metal finishing
(C) Impact wrench	2.7	^A	skid bolt removal
(D) Heavy duty right angle sander	3.6	3000	metal finishing and rough solder grinding
(E) Trimming shear	2.4	1800	metal trimming
(F) Light duty right angle sander	1.6	2400	metal finishing
(G) Jitterbug sander	3.9	8000	paint repair
(H) Vertical polisher	3.0	6000	paint polishing

^A Not a rotary or reciprocating power tool

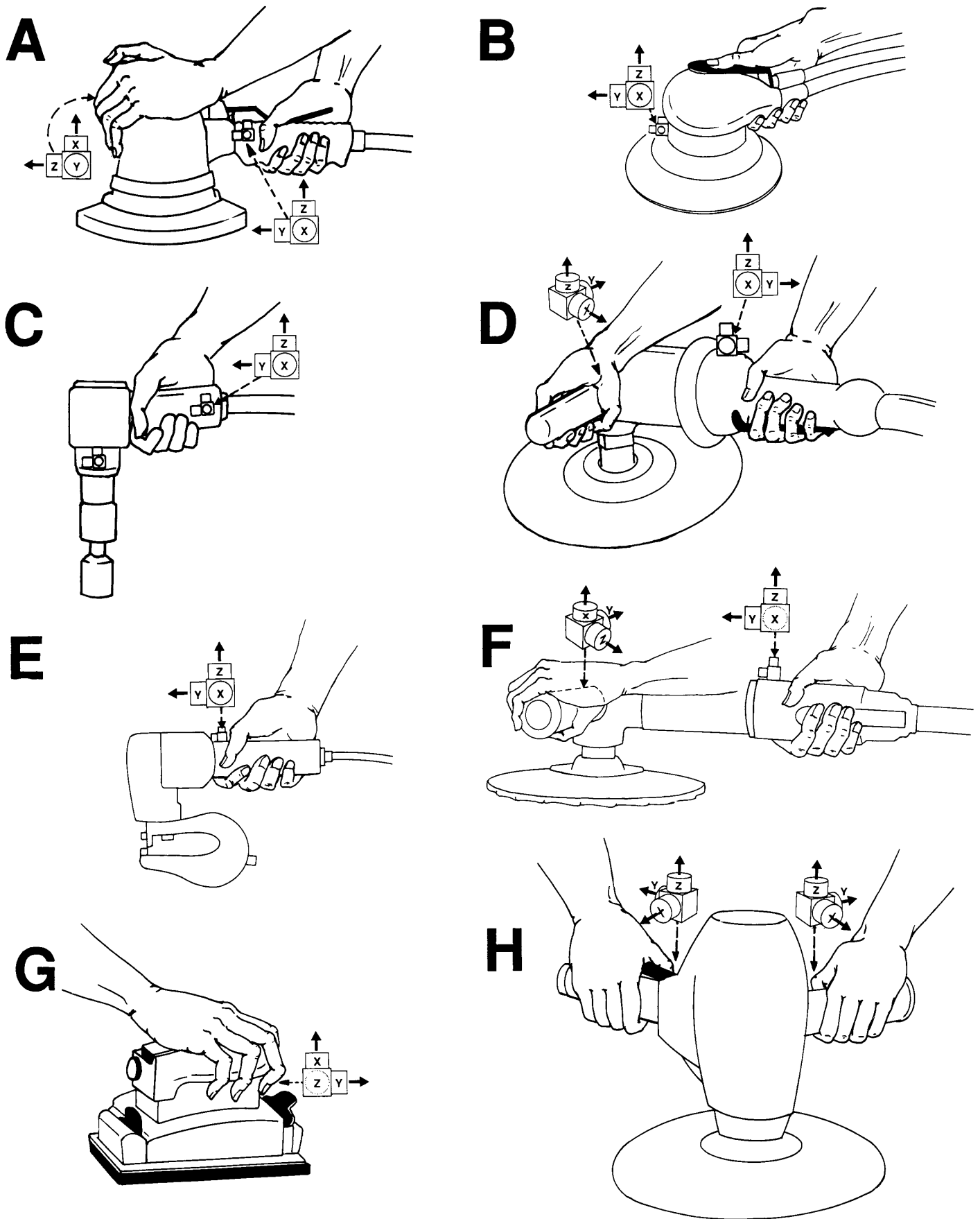

Figure 1—Handle and grip posture for the eight tools included in the survey. Accelerometer locations and corresponding coordinates in the x, y, and z axes are also included. (A) Hand grip orbital sander, (B) Palm grip orbital sander, (C) Impact wrench, (D) Heavy duty right angle sander, (E) Trimming shear, (F) Light duty right angle sander, (G) Jitterbug sander, (H) Vertical polisher.

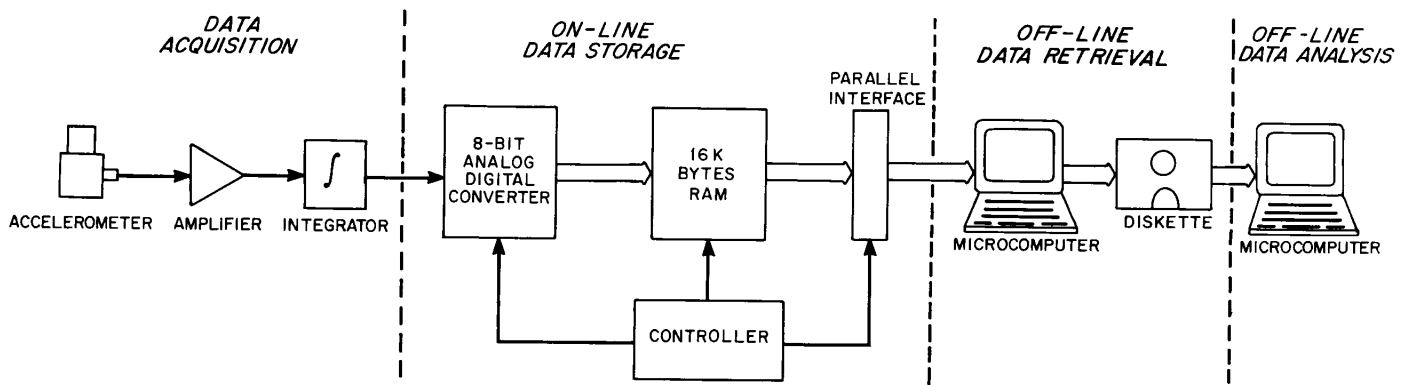

Figure 2—Block diagram of vibration exposure assessment scheme. Tool operation is sampled using an accelerometer attached to the hand tool, the acceleration waveform amplified, integrated, digitized, and stored in RAM on-line. Off-line the data is retrieved using a portable microcomputer and stored on diskette for later analysis.

served on an oscilloscope to verify the signal truly captured the tool operation. Afterwards the data was transferred off-line from the data logger to a Compaq portable microcomputer and stored on a diskette for subsequent analysis. Tool operation was indicated in the recorded data samples when the integrated acceleration value exceeded a threshold level set for each tool. Acceleration levels above threshold lasting 1 sec or less were rejected as artifact. Artifacts included very brief (less than 1 sec) impulses that may be produced during such activities as putting the tool aside.

Exposure time analysis included computing total observation time, total tool operation time, and number of times the tool was operated. The daily occupational exposure time was predicted using the total exposure time measured during the sampling period. The 4-hr frequency-weighted energy equivalent acceleration $(\alpha_{h,w})_{eq(4)}$, as used in the ISO 5349 standard, was then determined using the following equation:

$$(\alpha_{h,w})_{eq(4)} = \frac{\sqrt{T}}{2} (\alpha_{h,w})_{eq(T)} \quad (1)$$

where $(\alpha_{h,w})_{eq(T)}$ was the continuous frequency-weighted acceleration⁽¹¹⁾ measured off-line, and T was the predicted daily exposure time.

RESULTS

Representative time series plots for each tool are presented in Figure 3. Corresponding spectra are plotted in Figure 4. Table II summarizes the dominant fundamental frequencies and associated acceleration magnitudes in three coordinate axes for each of the tools tested. In Figure 5 the dominant fundamental frequencies measured for seven tools studied (excluding the impact wrench) were plotted against the frequency predicted using the manufacturers' supplied free running speed (see Table I). The predicted frequency was computed by dividing the tool free running speed (in rpm) by 60. Regression through the origin resulted in a linear regression coefficient of 0.88. Since the regression coefficient was less than one, this indicates that the measured frequencies tended to be somewhat less than the frequencies predicted from the free running speeds. The coefficient of determination was $R^2 = .93$, showing a good correlation between the actual and predicted dominant frequencies.

Table III contains the individual axis and vector total of the computed ISO 5349 frequency-weighted RMS vibration for continuous tool operation.

Vibration exposure analysis using the work sampling method described for three jobs is summarized in Table IV. These jobs included two metal finishing tasks and a rough solder grinding job. One metal finisher worked with a hand grip orbital sander while the other used a heavy duty right angle sander. The frequency-weighted 4-hr energy equivalent vibration, based on the maximum axis acceleration component, for the metal finishing job using the hand grip orbital sander was computed using Equation 1, resulting in 21 m/s^2 . Similarly, the 4-hr energy equivalent vibration was 2 m/s^2 for metal finishing using the heavy duty right angle sander and 11 m/s^2 for the rough solder grinding task.

DISCUSSION

Vibration levels at dead handles, accessory handles, or the tool bodies exceeded vibration levels at the main handles for all the tools tested (see Table III). No observable changes were noted in the fundamental frequency when various abrasives were used. Increased vibration levels, however, accompanied an increase in grit coarseness for the palm orbital sander. The jitterbug sander was tested using a fine 230 grit paper, yet it produced the greatest levels of vibration. It is anticipated that using more coarse papers would produce even greater levels for this type of tool. The company where this study was conducted decided to discontinue use of the jitterbug sander for regular production operations because of its high vibration levels and the availability of alternative sanding tools capable of performing the same function.

Total predicted exposure time exceeded 40 min for all three jobs studied (Table IV). The metal finishing task, using the hand grip orbital sander, exceeded 1 hr total predicted exposure time. The two metal finishing jobs had predicted daily exposure times of 42 and 63 min, respectively. These differences in vibration exposure time for the two similar jobs may be accounted for by the fact that different model hand tools were used for each job and because of differences in work materials and work methods. These differences in tools and work methods dramatically affected the frequency-weighted, 4-hr energy equivalent acceleration resulting in an order of magnitude difference between them. Lombard

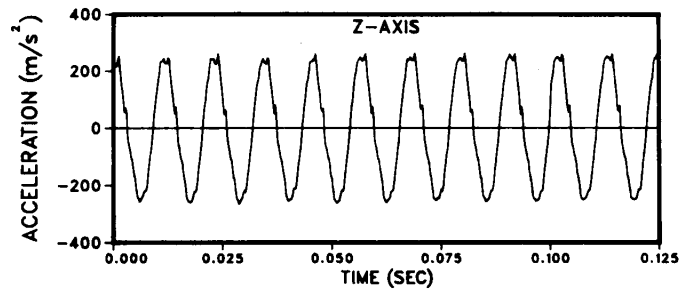

A

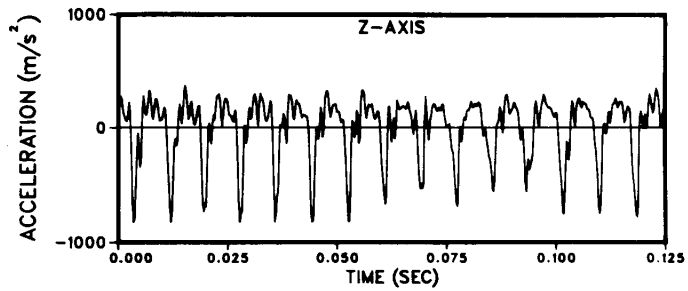

B

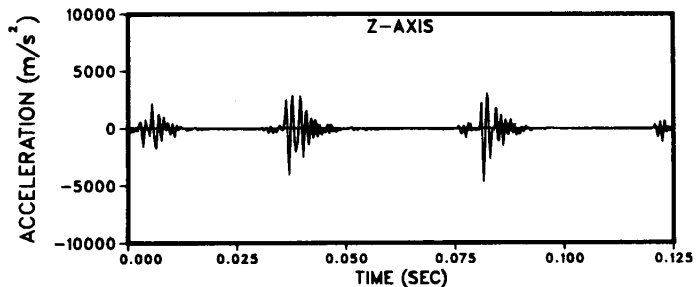

C

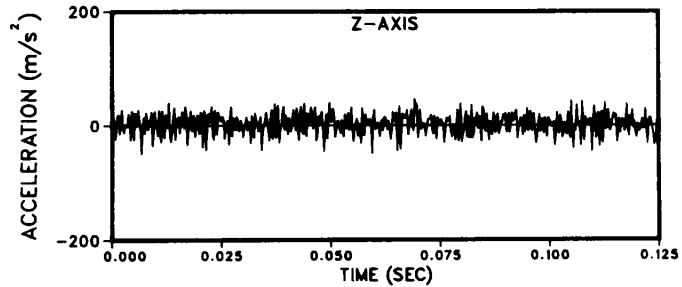

D

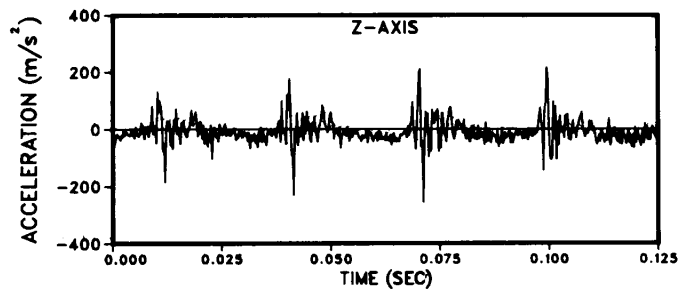

E

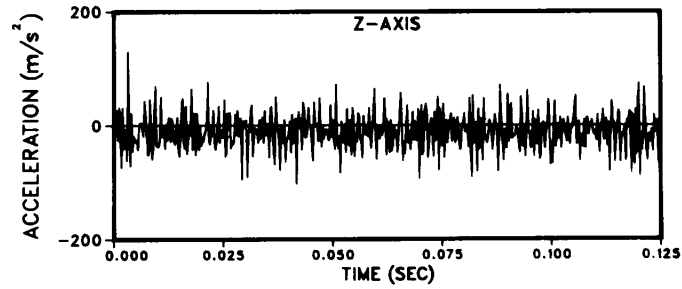

F

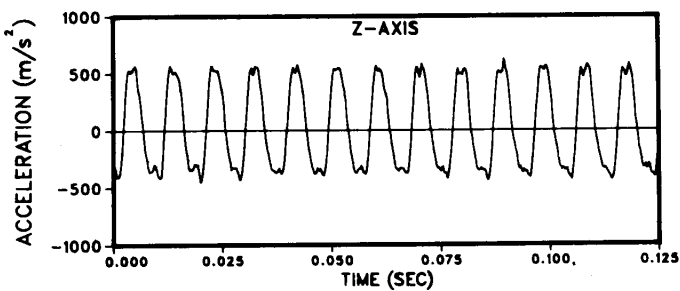

G

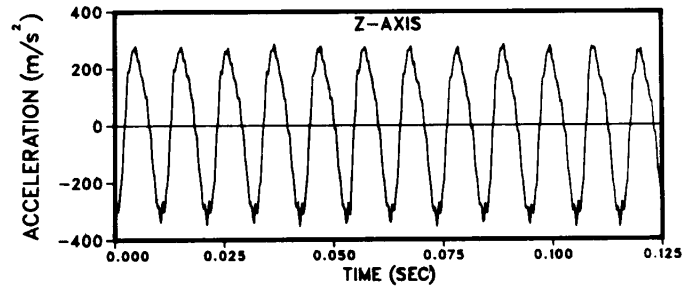

H

Figure 3—Representative time series data for the eight tools tested in the z-axis. (A) Hand grip orbital sander, (B) Palm grip orbital sander, (C) Impact wrench, (D) Heavy duty right angle sander, (E) Trimming shear, (F) Light duty right angle sander, (G) Jitterbug sander, (H) Vertical polisher.

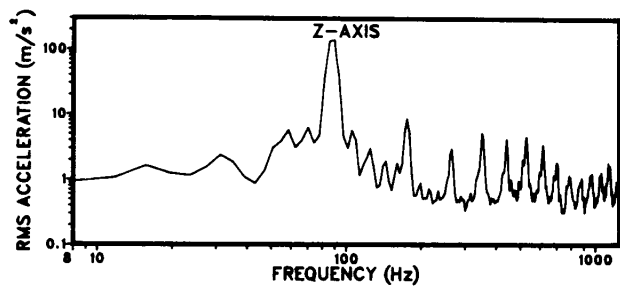

A

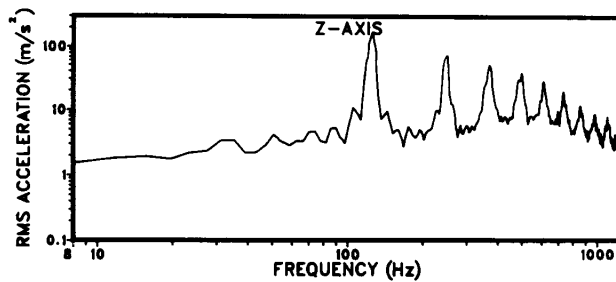

B

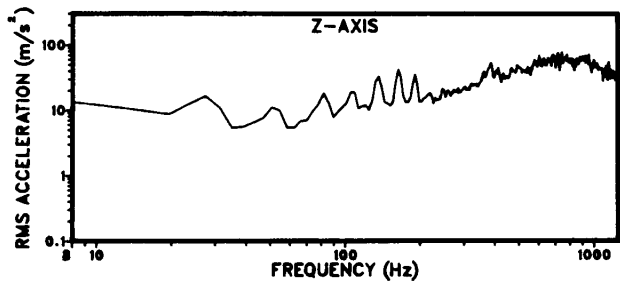

C

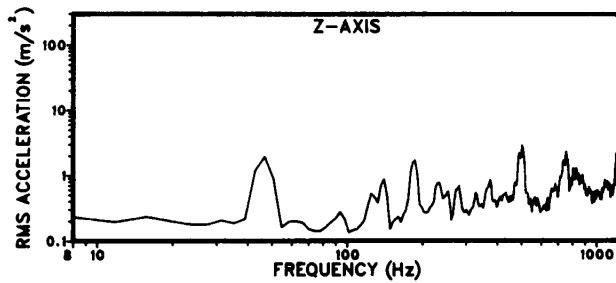

D

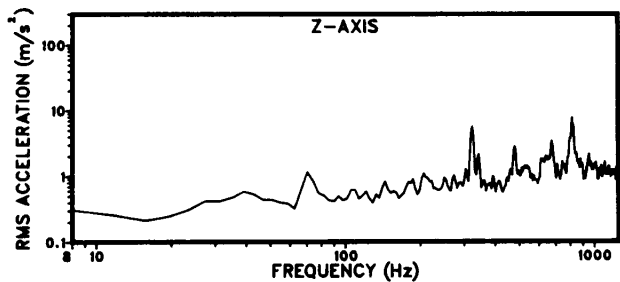

E

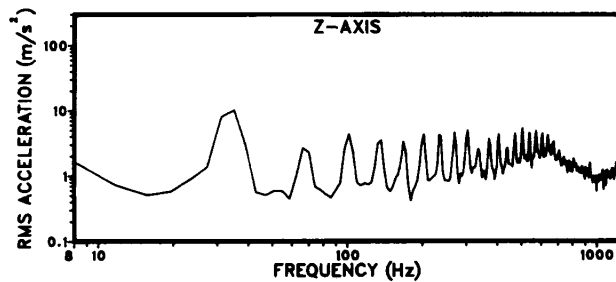

F

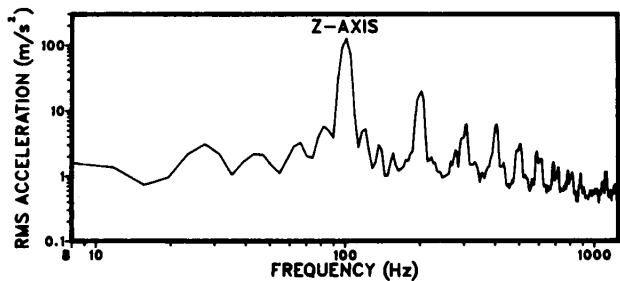

G

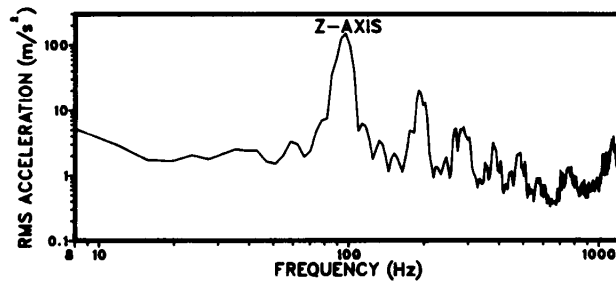

H

Figure 4—Representative power spectra for the eight tools tested in the z-axis. (A) Hand grip orbital sander, (B) Palm grip orbital sander, (C) Impact wrench, (D) Heavy duty right angle sander, (E) Trimming shear, (F) Light duty right angle sander, (G) Jitterbug sander, (H) Vertical polisher.

TABLE II
Summary of Dominant Frequency and Corresponding Individual Axis Acceleration Magnitude for Tools Tested

Tool Description	Handle	No. of Hands	Abrasive	Frequency (Hz)	Magnitude (m/s ²) Axis		
					X	Y	Z
Hand grip orbital sander	main	1	100 grit	90	50	60	190
		2	100 grit	90	30	70	220
	body	1	80 grit	90	70	50	120
		2	80 grit	90	40	90	110
		2	100 grit	90	90	110	140
		2	80 grit	90	60	80	90
Palm grip orbital sander	body	1	320 grit	150	120	70	40
	body	1	100 grit	150	120	70	170
	body	1	80 grit	150	115	60	120
Impact wrench	body	2	locked spindle	50	10	10	10
Heavy duty right angle sander	main	2	80 grit	45	5	2	2
	dead	2	80 grit	45	5	6	6
	main	2	grinding disc	80	90	70	40
	dead	2	grinding disc	80	40	50	80
Trimming shear	main	1	blade	35	6	15	10
Light duty right angle sander	main	2	fine disc	70	3	2	1
	dead	2	fine disc	70	2	6	7
Jitterbug sander	body	1	230 grit	100	290	110	130
Vertical polisher	right	2	polishing pad	100	20	20	20
	left	2	polishing pad	100	30	20	150

and Holt⁽¹²⁾ found that hand-held vibration tests by different laboratories on the same model chain saw for a given direction varied by more than 200% in the same octave bands. They observed much smaller variations between laboratories when using the ISO frequency-weighted acceleration sum of the three components. The vibration exposure method used here cannot only be used for measuring actual exposure for individual workers and

tasks but may also be used for predicting ($\alpha_{h,w})_{cq(4)}$ for a given change in the work standard or job rotation by remeasuring exposure time (T).

Dominant vibration fundamental frequencies for all the tools measured in this study occurred within a narrow frequency range between 35 Hz and 150 Hz. Harmonics of these fundamental frequencies were also present in the spectra, although the magnitude of the harmonics were far less than the fundamental frequency component magnitudes (Figure 4). The fundamental frequencies in this limited frequency range were closely associated with, or slightly less than, the tool free run speeds provided by the tool manufacturers, as shown in Figure 5. Miwa et al.⁽¹³⁾ similarly found the predominant vibration frequency component for a portable pneumatic grinder that rotated at 6000 to 7800 rpm was in the 100 Hz region, which closely corresponded to the tool rotation speed. Although only seven tools were included, these results indicated that use of manufacturer-supplied free running tool speeds may be a practical method for initially estimating the frequency where most of the vibration energy is contained for these types of rotary action tools. This may be useful in practice, for example, when selecting vibration isolation gloves and accessories for specific rotary and reciprocating abrasive power hand tools. The fundamental frequency of the power hand tool may be compared with the frequency range that the protective device effectively provides isolation. This method is not recommended, however, in place of direct hand tool vibration measurements for

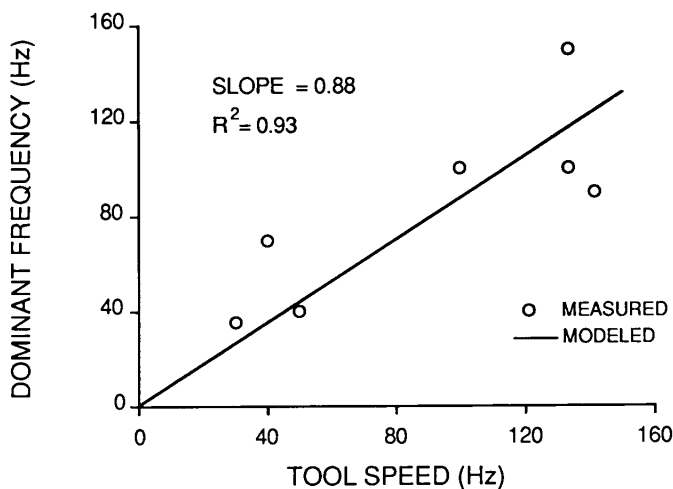

Figure 5—Plot of rotary and reciprocating tool dominant fundamental frequencies versus rated tool free running speed (n=7).

worker vibration exposure assessment as specified in hand-arm vibration exposure standards and guidelines. The vibration dosage the hand receives consists of the entire spectral distribution in three orthogonal directions, the mechanical coupling between the hand and the tool, the grip force, orientation, ambient and tool temperature, the use of gloves, and the condition and maintenance of the tool.

The relative effects of hand-transmitted vibration and ergonomic stress factors^(14,15) are often difficult to separate because many jobs using vibrating hand tools also involve considerable use of the upper limb. For instance, vibrating hand tool operators may also have to assume awkward postures dictated by a specific tool handle location and workpiece orientation. Vibrating power tool handles and triggers may introduce contact stress from sharp

TABLE III
Summary of Frequency-Weighted Individual Axis and Total Vibration

Tool Description	Handle	No. of Hands	Abrasive	Frequency-Weighted Continuous RMS Acceleration (m/s ²)			
				Axis			Total
				X	Y	Z	
Hand grip orbital sander	main	1	100 grit	17.7	21.3	67.8	73.2
		2	100 grit	6.9	16.6	40.9	44.6
	body	1	80 grit	23.5	29.4	72.5	81.7
		2	80 grit	16.5	26.1	38.9	49.6
		2	100 grit	21.4	23.9	32.3	45.5
		2	80 grit	27.1	26.8	30.1	48.5
Palm grip orbital sander	body	1	320 grit	20.0	11.3	20.8	30.9
	body	1	100 grit	18.0	10.4	25.3	32.7
	body	1	80 grit	25.4	15.3	35.6	46.3
Impact wrench	grip	2	locked	17.9	10.5	12.2	24.0
	body	2	spindle	29.3	20.5	35.3	50.3
Heavy duty right angle sander	main	2	80 grit	2.7	2.9	1.9	3.9
	dead	2	80 grit	3.6	4.3	4.5	7.2
	main	2	grinding disc	23.0	13.3	13.4	29.7
	dead	2	grinding disc	8.9	20.5	19.3	29.5
Trimming shear	main	1	blade	5.0	5.8	5.4	9.4
Light duty right angle sander	main	2	fine disc	1.9	1.1	1.1	2.4
	dead	2	fine disc	10.8	16.4	14.0	24.1
Jitterbug sander	body	1	230 grit	51.5	13.5	51.1	73.8
Vertical polisher	right	2	polishing	7.0	4.1	5.6	9.8
	left	2	pad	8.8	7.3	32.9	34.8

TABLE IV
Vibration Exposure Time Analysis

Job Title	Tool Description	Elapsed Time ^A (min)	Total Tool Operating Time ^A (min)	No. of Observations	Mean Operating Time ^B (sec)	Predicted Daily Exposure Time ^C (min)
Metal finishing	hand grip orbital sander (80 grit)	47	6.12	75	4.9 (SD=3.7)	62.9
Rough solder grinding	heavy duty right angle sander (grinding disc)	73	7.53	69	6.6 (SD=2.3)	49.7
Metal finishing	heavy duty right angle sander (80 grit)	63	5.47	41	8.0 (SD=5.2)	42.1

^A Time measured in seconds is presented in terms of minutes.

^B Mean tool operating time was computed by summing tool operation time during the observation period and dividing by the number of observations.

^C Predicted daily exposure time was computed by multiplying 480 min times the total tool operating time, divided by the elapsed time.

edges against the fingers or palm. The hands may also be exposed to cold air produced from pneumatic tool exhaust outlets.

The tool illustrated in Figure 1 (B) shows the grip posture assumed by the operator, holding the tool by the air hose connector in order to use a power grip. As a result of recommendations based on this investigation, the palm grip orbital sander was redesigned by enlarging its handle and providing a resilient covering material in order to eliminate contact stress and provide a power grip. The grip posture shown in Figure 1 (G) is a pinch grip which was the posture originally intended for this tool.

In addition to the physical trauma caused by ergonomic stressors, these ergonomic stress factors can also adversely affect vibration transmission to the hand tool operator, as well as vibration exposure. For example, forceful exertions may result in increased vibration transfer to the tool operator's hand and arm because of increased coupling between the vibrating handle and the hand. Highly repetitive work can affect vibration exposure by increasing accumulated doses of repeated exposures to vibration. These interactions have certainly complicated the study of ergonomic stress factors and their combined effects with hand-transmitted vibration.

SUMMARY

This study has demonstrated a practical procedure for assessing occupational vibration exposure on the job by work sampling tool operation to obtain vibration exposure time on-line and separately measuring vibration acceleration and frequency spectra for each tool off-line. Some tools used in similar operations produced more vibration than others. Tools producing the least level of vibration exposure should be substituted whenever possible. The rotary and reciprocating vibrating power hand tools studied had distinct dominant fundamental frequencies occurring in a narrow frequency range between 35 Hz and 150 Hz. These results suggest that the frequency of major vibration components can sometimes be estimated on the basis of tool rotation speeds. Additional studies of a larger number of tools are needed, however, in order to produce predictive models.

ACKNOWLEDGMENT

The battery operated digital data logger was designed and constructed by Charles B. Woolley. The authors also wish to thank Bryan Buchholz and Yair Lifshitz for their assistance.

REFERENCES

1. **American Conference of Governmental Industrial Hygienists:** TLV for Hand-Arm (Segmental) Vibration. *Documentation of the Threshold Limit Values*. Cincinnati, Ohio: American Conference of Governmental Industrial Hygienists, 1990.
2. **International Organization for Standardization:** *Guidelines for the Measurement and Assessment of Human Exposure to Hand-Transmitted Vibration* (ISO/DIS 5349). Switzerland: International Organization for Standardization, 1986.
3. **American National Standards Institute:** *Guide for the Measurement and Evaluation of Human Exposure to Vibration Transmitted to the Hand* (ANSI S3.34-1986). New York: American National Standards Institute, 1986.
4. **Lukas, E.:** Lesion of the Peripheral Nervous System Due to Vibration. *Work Environ. Health*. 7(1):67-79 (1970).
5. **Rothfleisch, S. and D. Sherman:** Carpal Tunnel Syndrome: Biomechanical Aspects of Occupational Occurrence and Implications Regarding Surgical Management. *Orthop. Rev.* 7(6): 107-109 (1978).
6. **Cannon, L.J., E.J. Bernacki, and S.D. Walter:** Personal and Occupational Factors Associated with Carpal Tunnel Syndrome. *J. Occup. Med.* 23(4): 255-258 (1981).
7. **Armstrong, T.J., L.J. Fine, R.G. Radwin, and B.S. Silverstein:** Ergonomics and the Effects of Vibration in Hand-Intensive Work. *Scand. J. Work, Environ. Health*. 13: 286-288 (1987).
8. **National Institute for Occupational Safety and Health:** *Vibration White Finger Disease in U.S. Workers Using Pneumatic Chipping and Grinding Hand Tools II: Engineering Testing* (DHHS [NIOSH] Publication No. 82-101). Cincinnati, Ohio: National Institute for Occupational Safety and Health, 1982.
9. **Radwin, R.G. and T.J. Armstrong:** Assessment of Hand Vibration Exposure on an Assembly Line. *Am. Ind. Hyg. Assoc. J.* 46(4): 211-219 (1985).
10. **Schwartz, M. and L. Shaw:** *Signal Processing: Discrete Spectral Analysis, Detection, and Estimation*. New York: McGraw-Hill, 1975.
11. **International Organization for Standardization:** *Revised Third Draft Proposal for Human Response Vibration Measuring Instrumentation* (ISO/DP 8041). 1984.
12. **Lombard, R. and S. Holt:** Measurement of Chain Saw Handle Vibration. In *Vibration Effects on the Hand and Arm in Industry*, edited by A.J. Brammer and W. Taylor. New York: John Wiley & Sons, 1982. pp. 203-209.
13. **Miwa, T., Y. Yonekawa, A. Nara, K. Kanada, and K. Baba:** Vibration Isolators for Portable Vibrating Tools, Part 1. A Grinder. *Ind. Health*. 17: 85-101 (1979).
14. **Armstrong, T.J., R.G. Radwin, D.J. Hansen, and K.W. Kennedy:** Repetitive Trauma Disorders: Job Evaluation and Design. *Hum. Factors*. 28(3): 325-336 (1986).
15. **Armstrong, T.J.:** *An Ergonomics Guide to Carpal Tunnel Syndrome*. Akron, Ohio: American Industrial Hygiene Association, 1983.